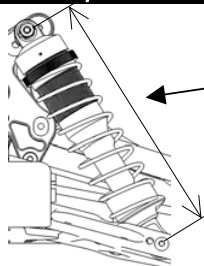
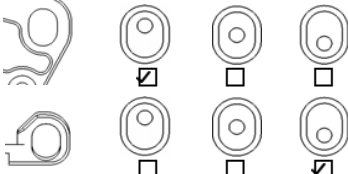
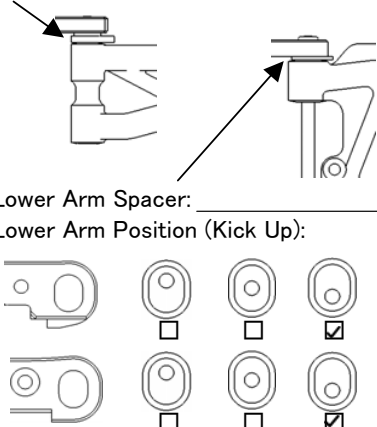
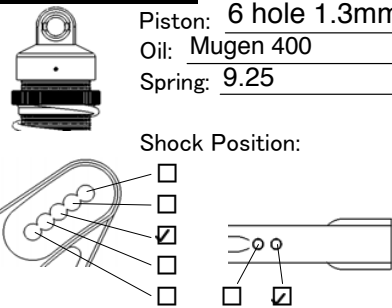
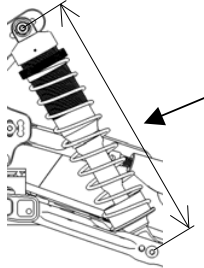
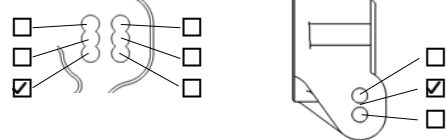
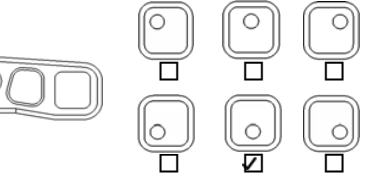

<b>Name:</b> Adam Drake	<b>Track Conditions</b>		<b>Result</b>
<b>Date:</b> 4-26-2015	<b>Size:</b> <input checked="" type="checkbox"/> Open <input type="checkbox"/> Med. <input type="checkbox"/> Tight	<b>Traction:</b> <input type="checkbox"/> High <input type="checkbox"/> Med. <input checked="" type="checkbox"/> Low	<b>Race Time / Lap:</b> _____
<b>Track:</b> Psycho Nitro Blast	<b>Surface:</b> <input type="checkbox"/> Smooth <input type="checkbox"/> Med. <input checked="" type="checkbox"/> Bumpy		<b>Best Lap (1Lap):</b> _____

<b>Front Suspension</b>	Ride Height: 25mm Toe Angle: 1 degree out Kingpin Ball Spacer(Upper): 1mm (Lower): 1mm Wheel Hub: std. Anti Roll Bar: 2.3mm Upper Arm Spacer: 2mm  Rebound Stop: 103.5mm Lower Arm Spacer: _____ Lower Arm Position (Kick Up): _____
Upright: <input checked="" type="checkbox"/> E2129 <input type="checkbox"/> E2105-B Tension Rod: <input type="checkbox"/> E2107A(Long) <input checked="" type="checkbox"/> E2107B(Short) Upper Arm Position: 	

<b>Front Shocks</b>	Piston: 6 hole 1.3mm Oil: Mugen 400 Spring: 9.25 Shock Position:  Pivot Ball Position: <input checked="" type="checkbox"/> Front <input type="checkbox"/> Rear Damper Stay: <input type="checkbox"/> E2502(Aluminum) <input checked="" type="checkbox"/> E2511(CFRP)
---------------------	--

<b>Steering Ackerman</b>	<input type="checkbox"/> <input checked="" type="checkbox"/> <input type="checkbox"/> <input type="checkbox"/> <input type="checkbox"/> <input type="checkbox"/>
--------------------------	---

<b>Rear Suspension</b>	Ride Height: 27mm Camber Angle: -3 degrees Wheel Hub: Std. Anti Roll Bar: 2.7mm Lower Arm Spacer: 0  Rebound Stop: 119mm Upright Spacer: 4mm Upright: <input type="checkbox"/> E2131 <input type="checkbox"/> Other aluminum hub Lower Arm Position (Toe Angle): _____
Upper Arm Position: 	

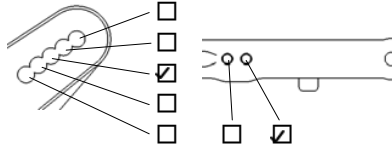
<b>Rear Shocks</b>	Piston: 6 hole 1.3mm Oil: Mugen 350 Spring: 10.25 Shock Position:  Pivot Ball Position: <input checked="" type="checkbox"/> Front <input type="checkbox"/> Rear Damper Stay: <input type="checkbox"/> E2522(Aluminum) <input checked="" type="checkbox"/> E2523(CFRP)
--------------------	---

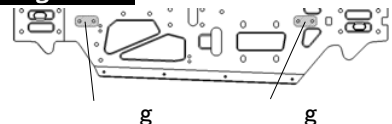
<b>Weight</b>	 _____ g          _____ g
---------------	--

<b>Engine</b>	Type: Novarossi Mito 4 Gasket: _____ Muffler: 9901 / 41021 Engine Mount: <input type="checkbox"/> E0701(Standard) <input type="checkbox"/> E2701(One Piece)	Plug: Novarossi C6TGC Reducer: 7.5mm Fuel: Flash Point 30%
---------------	--	--

<b>Diff. Oil</b>	Front: Mugen 5,000          O-Ring: _____ pcs. Center: Mugen 5,000          _____ pcs. Rear: Mugen 3,000          _____ pcs.
------------------	--

<b>Tires</b>	<b>Front</b> Type: Pro-Line Blockade Compound: M3 Inserts: Pro-Line Wheel: Pro-Line	<b>Rear</b> Type: Pro-Line Blockade Compound: M3 Inserts: Pro-Line Wheel: Pro-Line
--------------	---	--

<b>Clutch</b>	Clutch Bell: 13          Spur Gear: 46 Clutch Shoes: Mugen E0710 Clutch Spring: One 1.05 and two 1.0mm
---------------	--

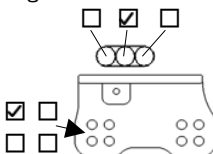
<b>Body/Wing</b>	Wing Position: <input checked="" type="checkbox"/> <input type="checkbox"/> <input type="checkbox"/>
Body: Pro-Line Wing: Pro-Line lexan	

<b>Comments</b>	42 / 12 ring and pinion front and rear. 40g of weight on the rear.
-----------------	--