

Name: Jason Ashton
Date: 3/7/2004
Track: Silver State

Track Conditions

Size: Open Med. Tight
 Traction: High Med. Low
 Surface: Smooth Med. Bumpy

Front Suspension

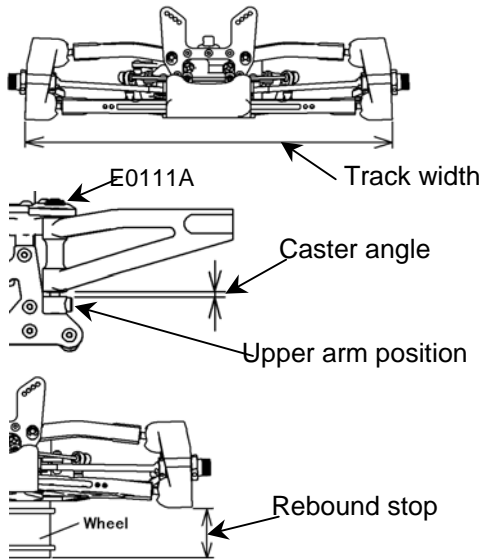

Track width 276 mm
 Camber angle -2 °
 Caster angle 1 mm
 Toe angle Out 1 °
 Rebound stop full mm
 Anti-roll bar Use 2.3 mm
 None
 Lower arm position E0105A (-1°)
 E0105B (-2°)
 E0105C (-3°)
 Upper arm position (E0111A)
 (High)
 (Low)

Front Shocks

Piston 1.5
 Oil # 350
 Spring Grey
 Spacer 6 mm
 Shock position

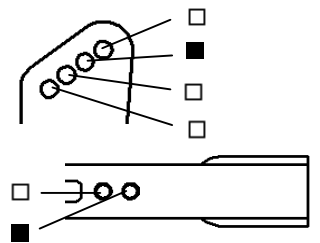

Steering Ackerman

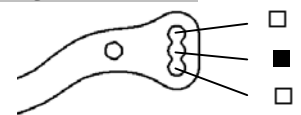

Rear Suspension

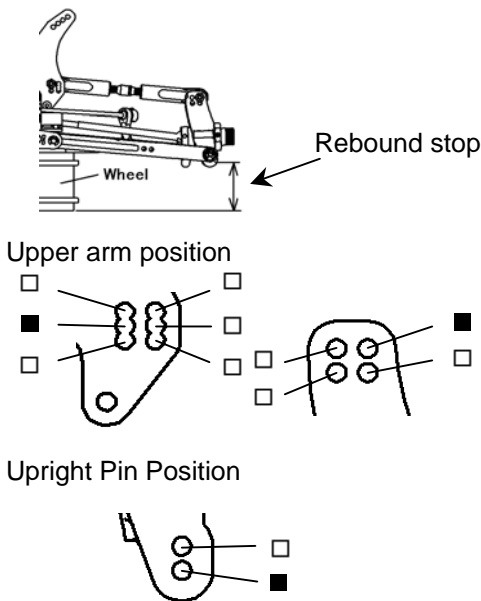

Camber angle -2 °
 Toe angle E0105D (2°)
 E0105E (2.5°)
 E0105F (3°)
 Rebound stop Full mm
 Anti-roll bar Use 2.8 mm
 None
 Caster angle (E0111C, E0111D)

 Wheelbase adjustment short mm
 Front

Rear Shocks

Piston 1.5
 Oil # 350
 Spring Grey
 Spacer 8 mm
 Shock position

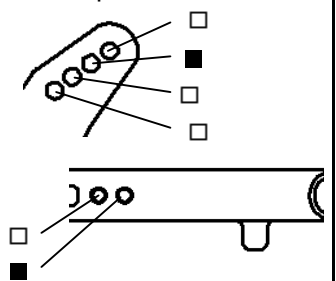

Wing Position

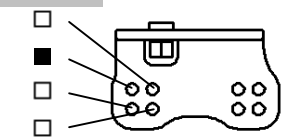

Engine

Type Rex P-5
 Gasket mm Muffle ###
 Plug Fuel 30%

Diff. Oil

Front # 5000 O-Ring 0 pcs. Other
 Center # 7000 0 pcs. Other
 Rear # 2000 0 pcs. Other

Tire

Front	Rear
Type <u>Pro-Line CrimeFighter</u>	Type <u>Pro-Line CrimeFighter</u>
Foam <u>Pro-Line</u>	Foam <u>Pro-Line</u>

Clutch

Clutch shoes Aluminium Other
 Spring 1.0 mm
 Clutch bell / Spur gear 13T / 46T

Result

Race time / Lap
 Best lap (1Lap)

Comments:

.....

