

Name: Scott Hughes
Date: 3/7/2004
Track: Silver State

Track Conditions

Size: Open Med. Tight
 Traction: High Med. Low
 Surface: Smooth Med. Bumpy

Front Suspension

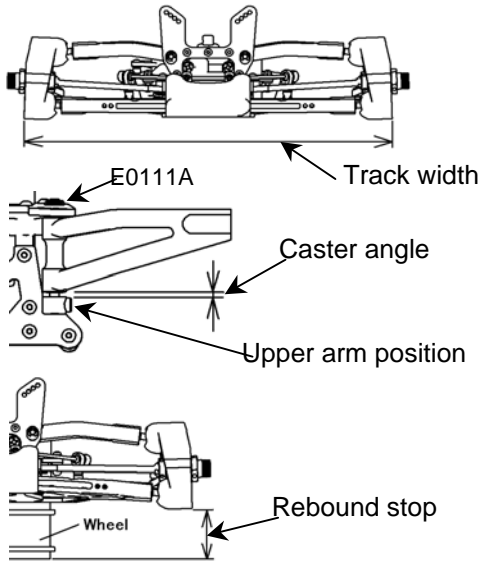

Track width 275 mm
 Camber angle -1 °
 Caster angle 2 mm
 Toe angle Out 2 °
 Rebound stop full mm
 Anti-roll bar Use 2.3 mm
 None
 Lower arm position E0105A (-1°)
 E0105B (-2°)
 E0105C (-3°)
 Upper arm position (E0111A)

 E0106A - E0106B (High)
 E0106C - E0106D (Low)

Front Shocks

Piston 1.5
 Oil # 400
 Spring Grey
 Spacer _____ mm
 Shock position

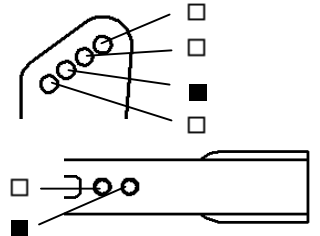

Steering Ackerman

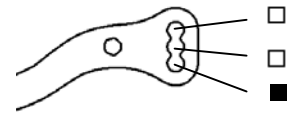

Rear Suspension

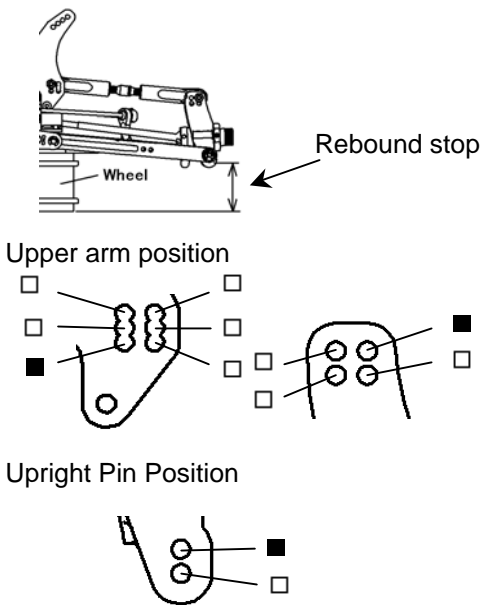

Camber angle -1 °
 Toe angle E0105D (2°)
 E0105E (2.5°)
 E0105F (3°)
 Rebound stop Full mm
 Anti-roll bar Use 2.8 mm
 None
 Caster angle (E0111C, E0111D)

 Wheelbase adjustment
center mm
 Front

Rear Shocks

Piston 1.5
 Oil # 350
 Spring Grey
 Spacer _____ mm
 Shock position

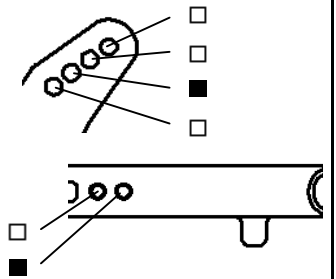

Wing Position

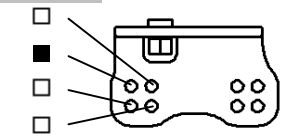

Engine

Type Siro Kanai
 Gasket _____ mm Muffle Kyosho T2050
 Plug _____ Fuel Odonnell 30%

Diff. Oil

Front # 5000 O-Ring 0 pcs. Other _____
 Center # 7000 0 pcs. Other _____
 Rear # 1500 0 pcs. Other _____

Tire

Front
 Type Pro-Line Crime Fighter
 Foam Pro-Line

Rear
 Type Pro-Line Crime Fighter
 Foam Pro-Line

Clutch

Clutch shoes Aluminium
 Other _____
 Spring 1.0 mm
 Clutch bell / Spur gear 13T / 46T

Result

Race time / Lap _____
 Best lap (1Lap) _____

Comments:

.....

