

**Name:** Kris Moore  
**Date:** \_\_\_\_\_  
**Track:** Action R/C

### Track Conditions

Size:  Open  Med.  Tight  
 Traction:  High  Med.  Low  
 Surface:  Smooth  Med.  Bumpy

### Front Suspension

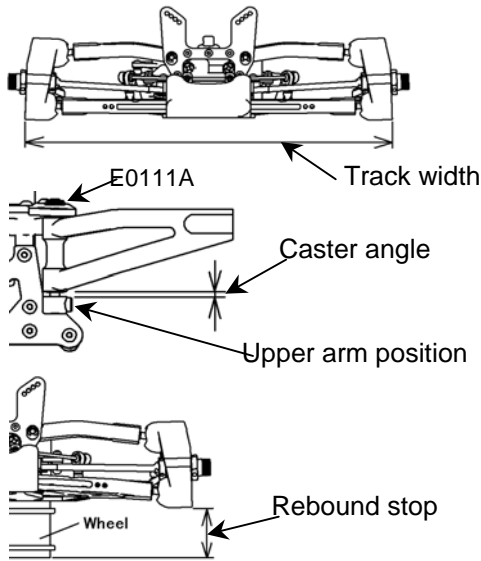

Track width 277 mm  
 Camber angle -2 °  
 Caster angle 2 mm  
 Toe angle Out 1 °  
 Rebound stop full mm  
 Anti-roll bar  Use 2.3 mm  
 None  
 Lower arm position  E0105A (-1°)  
 E0105B (-2°)  
 E0105C (-3°)  
 Upper arm position (E0111A)  
    
 E0106A - E0106B (High)  
 E0106C - E0106D (Low)

### Front Shocks

Piston 1.4  
 Oil # 350  
 Spring Grey  
 Spacer 6 mm  
 Shock position

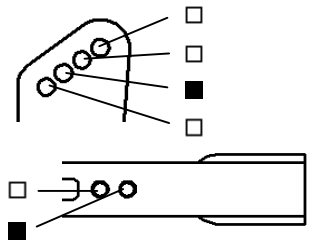

### Steering Ackerman

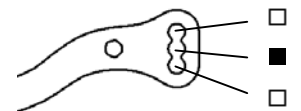

### Rear Suspension

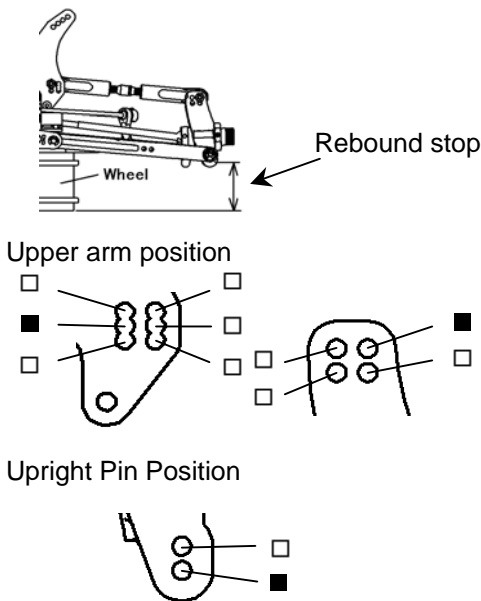

Camber angle -2.5 °  
 Toe angle  E0105D (2°)  
 E0105E (2.5°)  
 E0105F (3°)  
 Rebound stop full mm  
 Anti-roll bar  Use 2.8 mm  
 None  
 Caster angle (E0111C, E0111D)  
     
 Wheelbase adjustment 2.5 mm

### Rear Shocks

Piston 1.4  
 Oil # 300  
 Spring Grey  
 Spacer 7 mm  
 Shock position

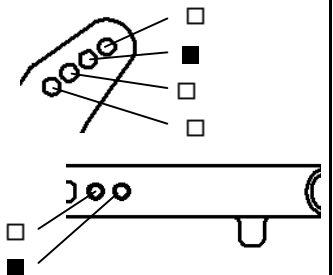

### Wing Position

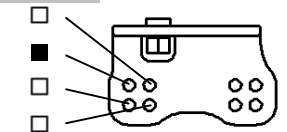

### Engine

Type OS  
 Gasket \_\_\_\_\_ mm Muffler ###  
 Plug \_\_\_\_\_ Fuel 30% Mugen

### Diff. Oil

Front # 5000 O-Ring 0 pcs.  Other \_\_\_\_\_  
 Center # 7000 0 pcs.  Other \_\_\_\_\_  
 Rear # 2000 0 pcs.  Other \_\_\_\_\_

### Tire

| Front                | Rear                 |
|----------------------|----------------------|
| Type <u>Pro-Line</u> | Type <u>Pro-Line</u> |
| Foam <u>Pro-Line</u> | Foam <u>Pro-Line</u> |

### Clutch

Clutch shoes  Aluminium  Other \_\_\_\_\_  
 Spring 1.0 mm  
 Clutch bell / Spur gear 13T / 46T

### Result

Race time / Lap \_\_\_\_\_  
 Best lap (1Lap) \_\_\_\_\_

### Comments:

.....  
 .....  
 .....