

**Name:** Mike Swauger  
**Date:** Starting Setup For Crystal Park  
**Track:** Crystal Park

**Track Conditions**

Size:	<input type="checkbox"/> Open	<input type="checkbox"/> Med.	<input type="checkbox"/> Tight
Traction:	<input type="checkbox"/> High	<input type="checkbox"/> Med.	<input type="checkbox"/> Low
Surface:	<input type="checkbox"/> Smooth	<input type="checkbox"/> Med.	<input type="checkbox"/> Bumpy

### Front suspension

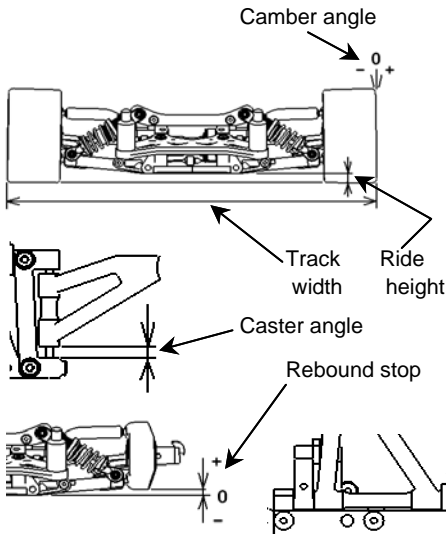

Track width 252 mm  
 Ride height 5 mm  
 Camber angle -2.0 °  
 Caster angle 3 mm  
 Toe angle out 1 °  
 Rebound stop 0 mm  
 Bump stop  
 None  Use  
 Lower arm spacer 0 mm  
 Upper arm position 0 mm

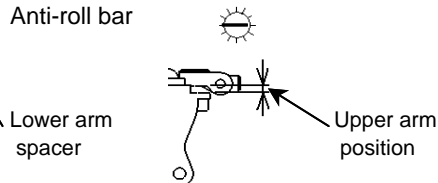

### Front shock

Piston Stock  
 Oil # 600  
 Springs White  
 Shock position

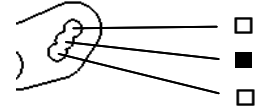

### Steering ackerman

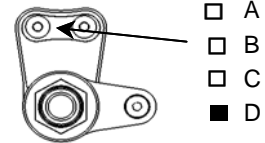

### Rear suspension

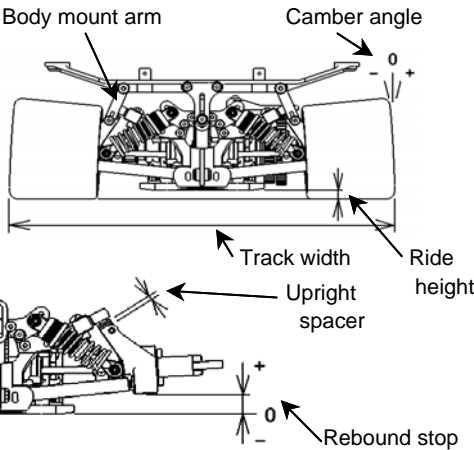

Track width 263 mm  
 Ride height 6 mm  
 Camber angle -3 °  
 Toe angle in 1.5 °  
 Rebound stop 9 mm  
 Bump stop  
 None  Use  
 Lower arm position(H0134)  
 4.5mm  5.5mm  6.5mm  
 Upright spacer 2 mm

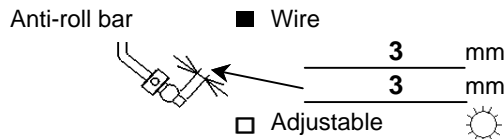

### Rear shock

Piston Stock  
 Oil # 600  
 Springs White  
 Shock position

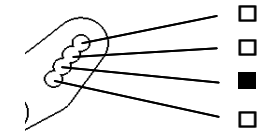

Body mount arm  Long(H0466C)  
 Short(H0466D)

### Engine

Type JP R 03  
 Gasket \_\_\_\_\_ mm Muffler Mugen P01006  
 Plug 7tf Fuel Mugen 30%

### Clutch

Clutch shoe  Black  Gray  Red  
 Centrifugal shoe Light weight  
 Spring Super hard  
 Clutch bell clearance 0.4 mm  
 Spring adj. nut position 9.3 mm

### Tire

<b>&lt;Front&gt;</b>	<b>&lt;Rear&gt;</b>
Type <u>Kawahara 35</u>	Type <u>Kawahara 35</u>
Dia.(start) <u>L 66 /R 66</u>	Dia.(start) <u>L 73 /R 73</u>
Dia.(finish) <u>L /R</u>	Dia.(finish) <u>L /R</u>

### Brake pad

Black  Yellow

### Body

Type PROTOform LOLA T530  
 Body position 10 mm  
 Rear spoiler 3 mm

### Drive ratio

Gear ratio Side pulley  
 1st. 16/49  25T  
 2nd. 20/46  26T

### Result

Race time / Lap \_\_\_\_\_  
 Best lap (1Lap) \_\_\_\_\_

### Comments:

**Use JP Alum. Clutch Bell**

.....  
 .....  
 .....