

Name: Mike Swauger
Date: 2005 Winternationals
Track: Ft. Myers

Track Conditions
 Size: Open Med. Tight
 Traction: High Med. Low
 Surface: Smooth Med. Bumpy

Front suspension

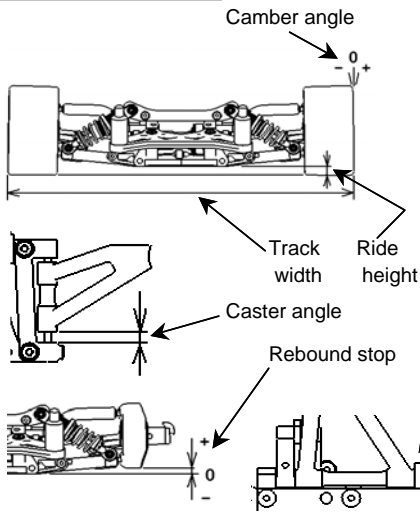

Track width 252 mm
 Ride height 4 mm
 Camber angle -2.0 °
 Caster angle 3 mm
 Toe angle out 0.5 °
 Rebound stop 0 mm
 Bump stop
 None Use
 Lower arm spacer 0 mm
 Upper arm position 0 mm

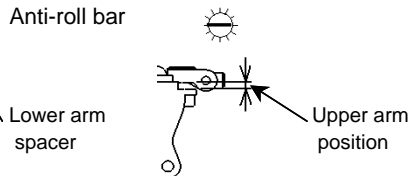

Front shock

Piston Stock
 Oil # 600
 Springs White
 Shock position

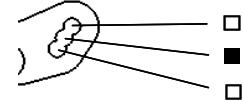

Steering ackerman

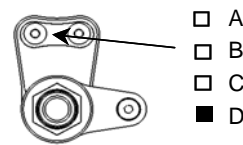

Rear suspension

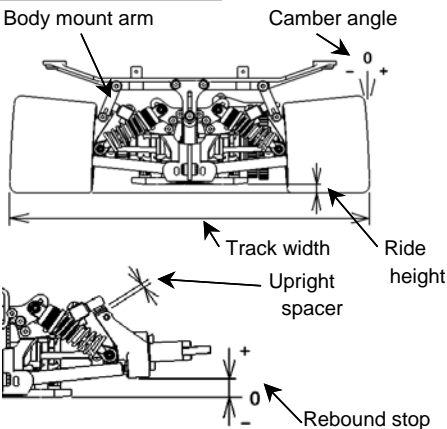

Track width 263 mm
 Ride height 5 mm
 Camber angle 3 °
 Toe angle in 1.5 °
 Rebound stop 9 mm
 Bump stop
 None Use
 Lower arm position(H0134)
 4.5mm 5.5mm 6.5mm
 Upright spacer 2 mm

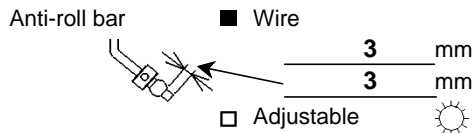

Rear shock

Piston Stock
 Oil # 600
 Springs White
 Shock position

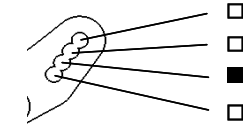

Body mount arm Long(H0466C)
 Short(H0466D)

Engine

Type JP FX R-O3
 Gasket _____ mm Muffler JP 2015
 Plug 7tf Fuel Mugen 30%

Clutch

Clutch shoe Black Gray Red
 Centrifugal shoe Light weight
 Spring JP
 Clutch bell clearance 0.4 mm
 Spring adj. nut position 0.8 mm

Tire

<Front>
 Type Kawahara 37
 Dia.(start) L 66 /R 66
 Dia.(finish) L /R

<Rear>
 Type Kawahara 37
 Dia.(start) L 73 /R 73
 Dia.(finish) L /R

Brake pad

Black Yellow

Body

Type PROTOform LOLA T530
 Body position 10 mm
 Rear spoiler 5 mm

Drive ratio

Gear ratio
 1st. 16/49 25T
 2nd. 20/47 26T

Result

Race time / Lap 26.5.08
 Best lap (1Lap) 11

Comments:

Used the JP Alum. Clutch Bell

.....

