

Name: Tim Long
Date: 2/16/2003
Track: Ft. Myers, FL Winter Nats

Track Conditions

Size: Open Med. Tight
 Traction: High Med. Low
 Surface: Smooth Med. Bumpy

Front suspension

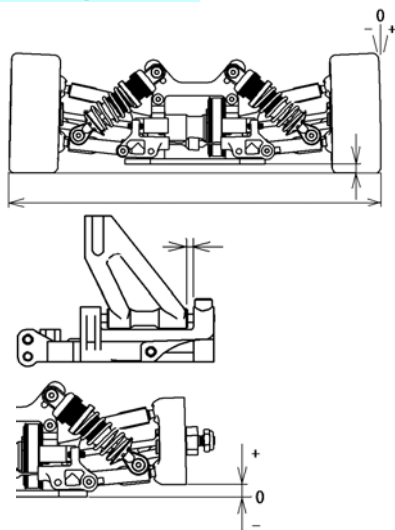

Track width 199 mm
 Ride height 4 mm
 Camber angle -1 °
 Caster angle 2 mm
 Toe angle out 1.0 °
 Rebound stop 2 mm
 Bump stop
 None Use

Anti-roll bar

Steering Ackerman (T0304)

A B C

Front shocks

Piston stock
 Oil # 600
 Spring Blue

Shock position

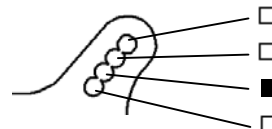

Front diff.

Gear diff.
 Oil # _____
 One way

Rear suspension

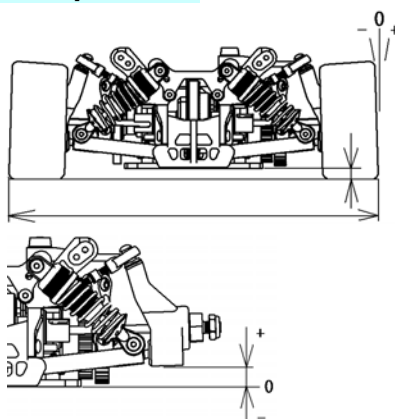

Track width 198 mm
 Ride height 5 mm
 Camber angle -3 °
 Toe angle 2 °
 Rebound stop 8 mm
 Bump stop
 None Use

Lower arm position(T0128,T0129)

4mm(A-A) 5mm(B-B) 6mm(C-C)

Anti-roll bar stock mm

Upper arm position



Rear shocks

Piston stock
 Oil # 600
 Spring Blue

Shock position

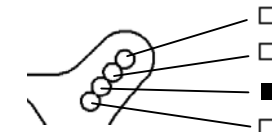

Rear diff.

Oil 100,000

Engine

Type _____
 Gasket _____ mm Muffler _____
 Plug _____ Fuel _____

Clutch

Red
 Black Gray
 Centrifugal shoe H0766
 Spring H0767

Tire

| | | | |
|--------------|-------------|--------------|-------------|
| Front | | Rear | |
| Type | <u>42</u> | Type | <u>42</u> |
| Dia.(start) | <u>L /R</u> | Dia.(start) | <u>L /R</u> |
| Dia.(finish) | <u>L /R</u> | Dia.(finish) | <u>L /R</u> |

Clutch bell clearance 0.4 mm
 Spring Adj. Nut position 8.87 mm

Body

Type _____
 Wing _____

Drive ratio

1st 16 / 47
 2nd 20 / 43

Brake pad

Black Yellow

Result

Race time / Lap _____
 Best lap (1Lap) _____

Comments:

.....

