

Track Conditions

- Size: Open Med. Tight
 Traction: High Med. Low
 Surface: Smooth Med. Bumpy

Name: Mike Swauger
 Date: 2005 Texas Biggie
 Track: RCRCNT

Front suspension

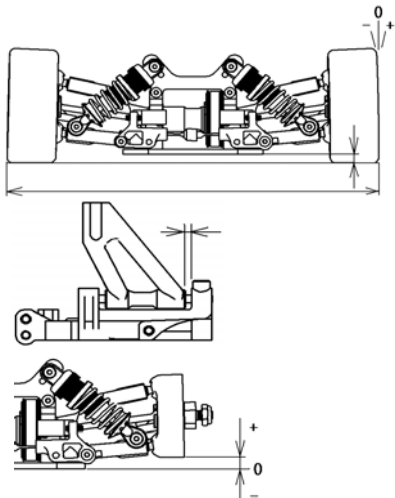

Track width 200 mm
 Ride height 6 mm
 Camber angle 2 °
 Caster angle 3 mm
 Toe angle .5 out °
 Rebound stop 1 mm
 Bump stop None Use

Anti-roll bar

Steering Ackerman (T0304)

- A B C

Front shocks

Piston Stock
 Oil # 600
 Spring Dark Blue

Shock position

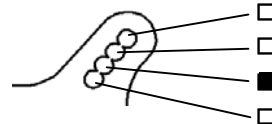

Front diff.

- Spool
 Oil # _____
 One way

Rear suspension

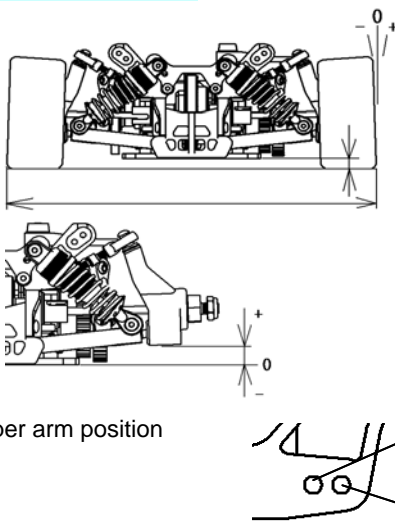

Track width 200 mm
 Ride height 7 mm
 Camber angle 3 °
 Toe angle 2 °
 Rebound stop 5 mm
 Bump stop None Use
 Lower arm position (T0128,T0129)
 4mm(A-A) 5mm(B-B) 6mm(C-C)
 Anti-roll bar Kaw mm

Upper arm position



Rear shocks

Piston Stock
 Oil # 600
 Spring Dark Blue

Shock position

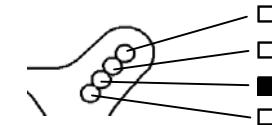

Rear diff.

Oil # 50,000

Engine

Type JP FX T-03
 Gasket _____ mm Muffler JP
 Plug 7tf Fuel Mugen 30%

Clutch

Clutch shoes Black Gray
 Centrifugal shoe Light
 Spring JP
 Clutch bell clearance 0.5 mm
 Spring Adj. Nut position 9.2 mm

Tire

| Front | | Rear | |
|--------------|--------------------|--------------|--------------------|
| Type | <u>Kawahara 45</u> | Type | <u>Kawahara 42</u> |
| Dia.(start) | <u>L /R 59.5</u> | Dia.(start) | <u>L /R 59</u> |
| Dia.(finish) | <u>L /R</u> | Dia.(finish) | <u>L /R</u> |

Body

Type Protoform Mazda 6
 Wing _____

Drive ratio

1st 21/59
 2nd 27/53

Brake pad

- Black Yellow

Result

Race time / Lap _____
 Best lap (1Lap) _____

Comments:

.....

