

Name: Mike Swauger
Date: 2005 Texas Biggie
Track: RCRCNT

Track Conditions

Size: Open Med. Tight
 Traction: High Med. Low
 Surface: Smooth Med. Bumpy

Front suspension

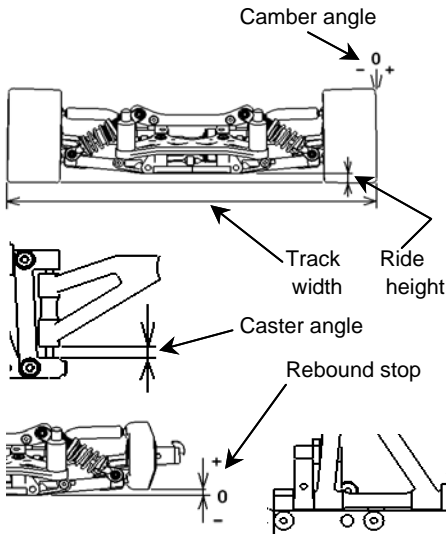

Track width 254 mm
 Ride height 7 mm
 Camber angle -2.0 °
 Caster angle 2 mm
 Toe angle out 1 °
 Rebound stop 0 mm
 Bump stop None Use
 Lower arm spacer 0 mm
 Upper arm position 0 mm
 Anti-roll bar

Front shock

Piston Stock
 Oil # 600
 Springs White
 Shock position

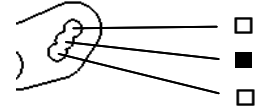

Steering ackerman

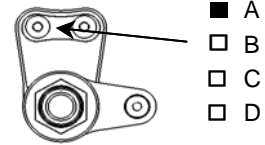

Rear suspension

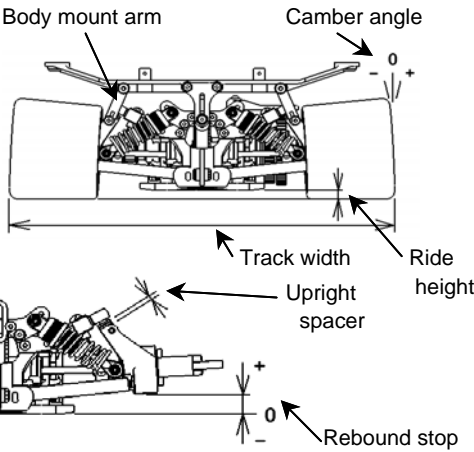

Track width 263 mm
 Ride height 8 mm
 Camber angle -3 °
 Toe angle in 3 °
 Rebound stop 9 mm
 Bump stop None Use
 Lower arm position(H0134)
 4.5mm 5.5mm 6.5mm
 Upright spacer 4 mm
 Anti-roll bar Wire None
 Adjustable

Rear shock

Piston Stock
 Oil # 600
 Springs White
 Shock position

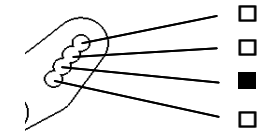

Body mount arm Long(H0466C)
 Short(H0466D)

Engine

Type JP R-03
 Gasket _____ mm Muffler JP 2015/w conical header
 Plug 7tf Fuel Mugen 30%

Clutch

Clutch shoe Black Gray Red
 Centrifugal shoe Light weight
 Spring Silver
 Clutch bell clearance 0.4 mm
 Spring adj. nut position 0.9 mm

Tire

<Front> Type Kawahara 40
 Dia.(start) L 67
 Dia.(finish) L /R

<Rear> Type Kawahara 35
 Dia.(start) L 73
 Dia.(finish) L /R

Brake pad

Black Yellow

Body

Type PROTOform LOLA T530
 Body position 10 mm
 Rear spoiler 5 mm

Drive ratio

Gear ratio Side pulley
 1st. 17/50 25T
 2nd. 20/45 26T

Result

Race time / Lap _____
 Best lap (1Lap) _____

Comments:

.....

