

Name: Mike Swauger
Date: 2005 Airtronics Race
Track: Revelation Raceway

Track Conditions

Size:	<input type="checkbox"/> Open	<input type="checkbox"/> Med.	<input type="checkbox"/> Tight
Traction:	<input type="checkbox"/> High	<input type="checkbox"/> Med.	<input type="checkbox"/> Low
Surface:	<input type="checkbox"/> Smooth	<input type="checkbox"/> Med.	<input type="checkbox"/> Bumpy

Front suspension

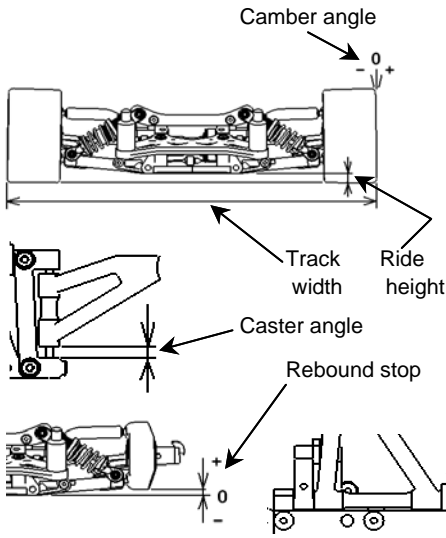

Track width 252 mm
 Ride height 4 mm
 Camber angle -2.0 °
 Caster angle 3 mm
 Toe angle 1 °
 Rebound stop 2 mm
 Bump stop
 None Use
 Lower arm spacer 3 mm
 Upper arm position 3 mm
 Anti-roll bar

Front shock

Piston Stock
 Oil # 600
 Springs White
 Shock position

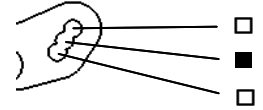

Steering ackerman

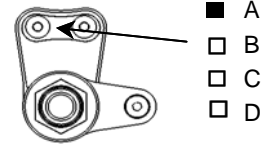

Rear suspension

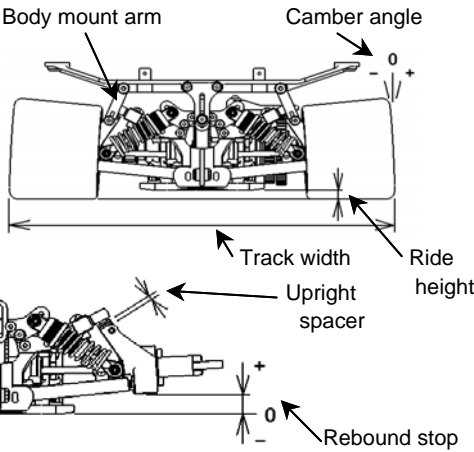

Track width 263 mm
 Ride height 5 mm
 Camber angle 3 °
 Toe angle 2 °
 Rebound stop 9 mm
 Bump stop
 None Use
 Lower arm position(H0134)
 4.5mm 5.5mm 6.5mm
 Upright spacer 2 mm
 Anti-roll bar Wire
 Adjustable

Rear shock

Piston Stock
 Oil # 600
 Springs White
 Shock position

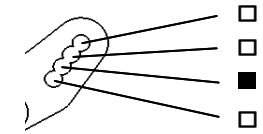

Body mount arm Long(H0466C)
 Short(H0466D)

Engine

Type JP FX R-03
 Gasket _____ mm Muffler JP 2015
 Plug 7tf Fuel Mugen 30%

Clutch

Clutch shoe Black Gray Red
 Centrifugal shoe Light weight
 Spring JP
 Clutch bell clearance 0.4 mm
 Spring adj. nut position 0.8 mm

Tire

<Front>	<Rear>
Type <u>Kawahara 40</u>	Type <u>Kawahara 37</u>
Dia.(start) <u>L 67 /R 67</u>	Dia.(start) <u>L 73 /R 73</u>
Dia.(finish) <u>L /R</u>	Dia.(finish) <u>L /R</u>

Brake pad

Black Yellow

Body

Type PROTOform LOLA T530
 Body position 10 mm
 Rear spoiler 5 mm

Drive ratio

Gear ratio Side pulley
 1st. 16/49 25T
 2nd. 20/46 26T

Result

Race time / Lap _____
 Best lap (1Lap) _____

Comments:

Used the JP Alum. Clutch Bell

.....

