

Name: Mike Strack
Date: Airtronics Race
Track: Revelation Raceway

Track Conditions
 Size: Open Med. Tight
 Traction: High Med. Low
 Surface: Smooth Med. Bumpy

Front suspension

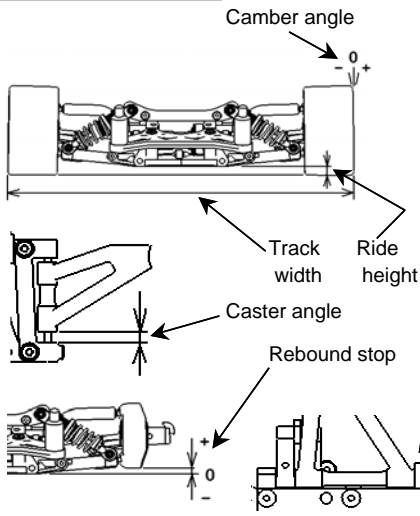

Track width 252 mm
 Ride height 5 mm
 Camber angle -2.0 °
 Caster angle 1 mm
 Toe angle out 1 °
 Rebound stop 2 mm
 Bump stop None Use
 Lower arm spacer 0 mm
 Upper arm position 0 mm

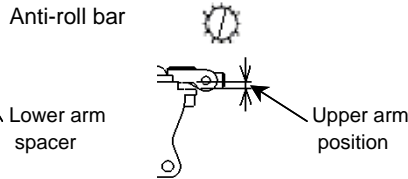

Front shock

Piston Stock
 Oil # 600
 Springs White
 Shock position

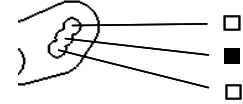

Steering ackerman

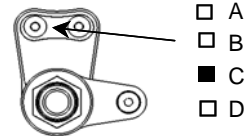

Rear suspension

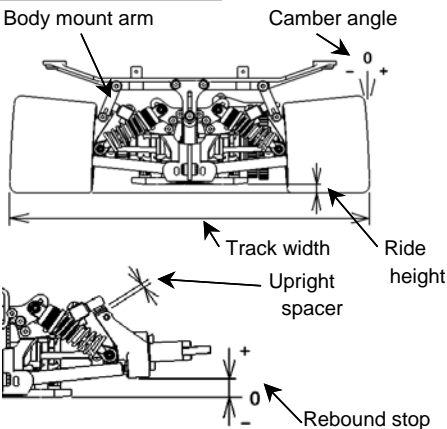

Track width 263 mm
 Ride height 6 mm
 Camber angle -3 °
 Toe angle in 1.5 °
 Rebound stop 9 mm
 Bump stop None Use
 Lower arm position(H0134)
 4.5mm 5.5mm 6.5mm
 Upright spacer 2 mm

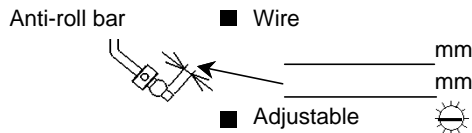

Rear shock

Piston Stock
 Oil # 600
 Springs White
 Shock position

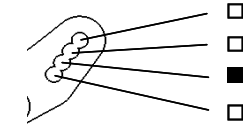

Body mount arm Long(H0466C)
 Short(H0466D)

Engine

Type _____
 Gasket _____ mm Muffler _____
 Plug _____ Fuel _____

Clutch

Clutch shoe Black Gray Red
 Centrifugal shoe Light weight
 Spring Silver
 Clutch bell clearance 0.4 mm
 Spring adj. nut position 0.8 mm

Tire

| | |
|-------------------------------|-------------------------------|
| <Front> | <Rear> |
| Type <u>Kawahara 40</u> | Type <u>Kawahara 40</u> |
| Dia.(start) <u>L 66 /R 66</u> | Dia.(start) <u>L 71 /R 71</u> |
| Dia.(finish) <u>L /R</u> | Dia.(finish) <u>L /R</u> |

Brake pad

Black Yellow

Body

Type PROTOform LOLA T530
 Body position 10 mm
 Rear spoiler 5 mm

Drive ratio

Gear ratio
 1st. 16/49 25T
 2nd. 20/45 26T

Result

Race time / Lap _____
 Best lap (1Lap) _____

Comments:

.....

