

**Track Conditions**

- Size:  Open  Med.  Tight  
 Traction:  High  Med.  Low  
 Surface:  Smooth  Med.  Bumpy

**Name:** Darin Ishitani  
**Date:** 2005 Airtronics Race  
**Track:** Revelation Raceway

**Front suspension**

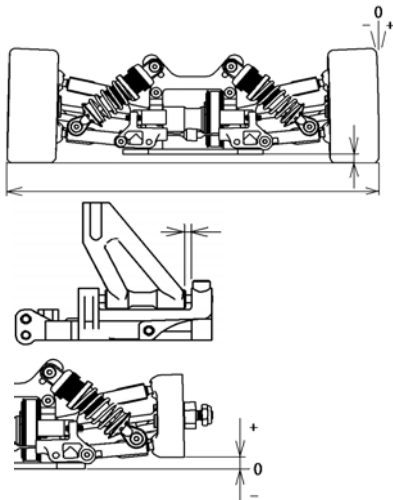

Track width 199 mm  
 Ride height 3 mm  
 Camber angle 2 °  
 Caster angle 1 mm  
 Toe angle .5out °  
 Rebound stop 1 mm  
 Bump stop  None  Use

Anti-roll bar

**Steering Ackerman (T0304)**

- A  B  C

**Front shocks**

Piston Stock  
 Oil # 700  
 Spring Dark Blue

Shock position

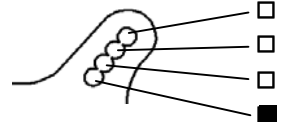

**Front diff.**

- Gear diff.

Oil # \_\_\_\_\_  
 One way

**Rear suspension**

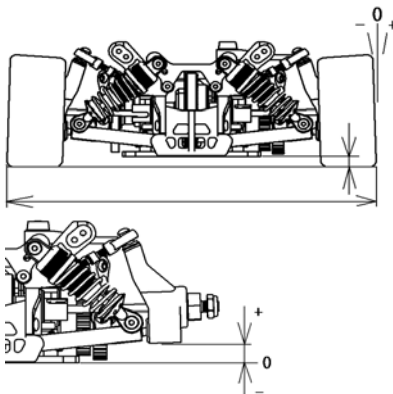

Track width 200 mm  
 Ride height 4 mm  
 Camber angle 3 °  
 Toe angle 2 °  
 Rebound stop 4 mm  
 Bump stop  None  Use

Lower arm position (T0128,T0129)

- 4mm(A-A)  5mm(B-B)  6mm(C-C)

Anti-roll bar none mm

Upper arm position



**Rear shocks**

Piston Stock  
 Oil # 800  
 Spring Dark Blue

Shock position

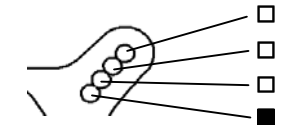

**Rear diff.**

Oil # 30,000

**Engine**

Type JP FX T-03  
 Gasket 7tf mm Muffler Mugen  
 Plug \_\_\_\_\_ Fuel Byrons 30%

**Clutch**

Clutch shoes  Black  Gray  
 Centrifugal shoe Light  
 Spring JP  
 Clutch bell clearance 0.4 mm  
 Spring Adj. Nut position 0.5 mm

**Tire**

Front	Type <u>Fast 45</u>	Rear	Type <u>Fast45</u>
	Dia.(start) <u>L /R</u> 58		Dia.(start) <u>L /R</u> 59.5
	Dia.(finish) <u>L /R</u>		Dia.(finish) <u>L /R</u>

**Body**

Type Protoform Mazda 6  
 Wing \_\_\_\_\_

**Drive ratio**

1st 21 / 59  
 2nd 27 / 53

**Brake pad**

- Black  Yellow

**Result**

Race time / Lap \_\_\_\_\_  
 Best lap (1Lap) \_\_\_\_\_

**Comments:**

Used MRX-4 Shocks

.....  
 .....  
 .....  
 .....

