

Name: Robbie Collins
Date: _____
Track: ALL

Track Conditions

Size: Open Med. Tight
 Traction: High Med. Low
 Surface: Smooth Med. Bumpy

Front suspension

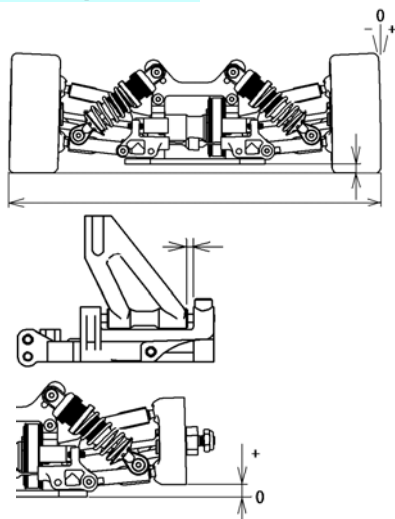

Track width 198 mm
 Ride height 5 mm
 Camber angle 2 °
 Caster angle 2 mm
 Toe angle out 0.5 °
 Rebound stop -1 mm
 Bump stop
 None Use

Anti-roll bar

Steering Ackerman (T0304)

A B C

Front shocks

Piston 1.2
 Oil # 600
 Spring stock

Shock position

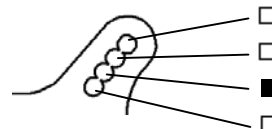

Front diff.

Gear diff.
 Oil # _____
 One way

Rear suspension

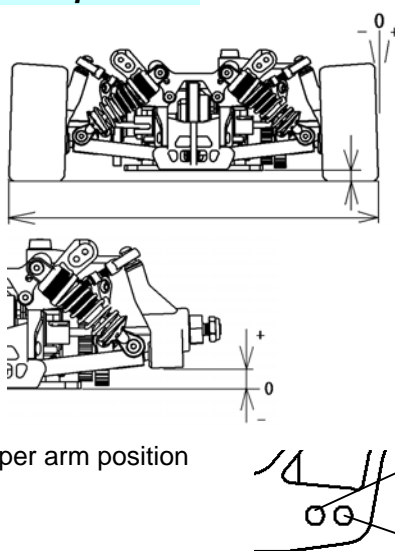

Track width 199 mm
 Ride height 6 mm
 Camber angle -4 °
 Toe angle -3 °
 Rebound stop 5 mm
 Bump stop
 None Use
 Lower arm position(T0128,T0129)
 4mm(A-A) 5mm(B-B) 6mm(C-C)
 Anti-roll bar 2 mm

Upper arm position



Rear shocks

Piston stock
 Oil # 600
 Spring stock

Shock position

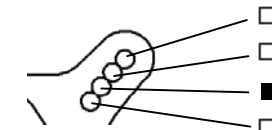

Rear diff.

Oil # stock

Engine

Type X-12 Series
 Gasket _____ mm Muffler Mugen
 Plug Rex 5 Fuel Mugen 40%

Clutch

Clutch shoes Black Gray
 Centrifugal shoe H0766
 Spring H0765

Tire

Front	Rear
Type <u>stock (37°)</u>	Type <u>stock (37°)</u>
Dia.(start) <u>L /R</u>	Dia.(start) <u>L /R</u>
Dia.(finish) <u>L /R</u>	Dia.(finish) <u>L /R</u>

Clutch bell clearance 0.4 mm
 Spring Adj. Nut position 0.8 mm

Body

Type _____
 Wing _____

Drive ratio

1st 17 / 47
 2nd 21 / 43

Brake pad

Black Yellow

Result

Race time / Lap _____
 Best lap (1Lap) _____

Comments:

.....

