

Name: Mike Swauger
Date: 2004 Sedan Nationals
Track: Woodville

Track Conditions

Size: Open Med. Tight
 Traction: High Med. Low
 Surface: Smooth Med. Bumpy

Front suspension

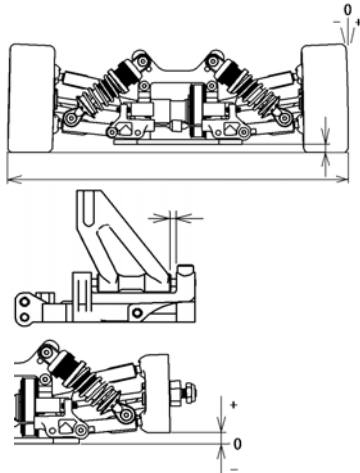

Track width 199 mm
 Ride height 4 mm
 Camber angle 2 °
 Caster angle 1 mm
 Toe angle 0.5 out °
 Rebound stop -1 mm
 Bump stop None Use

Anti-roll bar

Steering Ackerman (T0304)

A B C

Front shocks

Piston Stock
 Oil # 600
 Spring Grey

Shock position

Front diff.

Gear diff.
 Oil # _____
 One way

Rear suspension

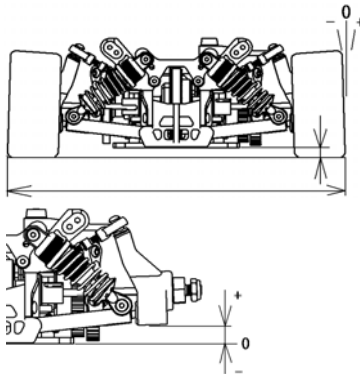

Track width 200 mm
 Ride height 4 mm
 Camber angle 4 °
 Toe angle 1 °
 Rebound stop 3 mm
 Bump stop None Use
 Lower arm position (T0128,T0129)
 4mm(A-A) 5mm(B-B) 6mm(C-C)
 Anti-roll bar Kawaha mm

Upper arm position
1.0 mm

Rear shocks

Piston Stock
 Oil # 600
 Spring Grey

Shock position

Rear diff.

Oil # 50,000

Engine

Type JP X-12
 Gasket _____ mm Muffler Mugen P01002
 Plug 8tf Fuel Mugen 30%

Clutch

Clutch shoes Black Gray
 Centrifugal shoe Light
 Spring Silver
 Clutch bell clearance 0.05 mm
 Spring Adj. Nut position 9 mm

Tire

Front		Rear	
Type	<u>Kawahara 45</u>	Type	<u>Kawahara 45</u>
Dia.(start)	<u>L /R 67.5</u>	Dia.(start)	<u>L /R 67.5</u>
Dia.(finish)	<u>L /R</u>	Dia.(finish)	<u>L /R</u>

Body

Type Protoform Mazda 6
 Wing Stock

Drive ratio

1st 22 / 58
 2nd 28 / 52

Brake pad

Black Yellow

Result

Race time / Lap 19
 Best lap (1Lap) _____

Comments:

.....

